

## Reference Specifications

AC Servo Drive      MINAS-B series  
with SynqNet Interface

Issued on May. 22, 2002

Motor Company  
Matsushita Electric Industrial Co., Ltd.  
7-1-1, Morofuku, Daito, Osaka, 574-0044, Japan  
TEL : +81-72-871-1212  
FAX : +81-72-870-3151



Table of Contents
-------------------

1. Scope .....	1			
2. Model symbol and Applicable motor .....	1			
3. Specifications				
3-1 General specifications .....	2			
3-2 Timing chart after power ON .....	3			
3-3 Timing chart of Servo ON/OFF at motor standstill (servo lock) .....	4			
3-4 Timing chart of Servo ON/OFF at motor in motion .....	4			
3-5 Dimensions .....	5			
3-6 Appearance and description .....	7			
4. Safety precautions in installing .....	8			
5. Safety precautions in operating .....	8			
6. Connector				
6-1 Power connector <table border="1" style="display: inline-table; vertical-align: middle;"><tr><td>X1</td></tr></table> <table border="1" style="display: inline-table; vertical-align: middle;"><tr><td>X2</td></tr></table> <table border="1" style="display: inline-table; vertical-align: middle;"><tr><td>X3</td></tr></table> .....	X1	X2	X3	9
X1				
X2				
X3				
6-2 Encoder connector <table border="1" style="display: inline-table; vertical-align: middle;"><tr><td>X4</td></tr></table> .....	X4	10		
X4				
6-3 Interface connector <table border="1" style="display: inline-table; vertical-align: middle;"><tr><td>X5</td></tr></table> .....	X5	11		
X5				
6-4 RS232 Serial communication connector <table border="1" style="display: inline-table; vertical-align: middle;"><tr><td>X6</td></tr></table> .....	X6	12		
X6				
6-5 SynqNet Communication connector <table border="1" style="display: inline-table; vertical-align: middle;"><tr><td>X7</td></tr></table> <table border="1" style="display: inline-table; vertical-align: middle;"><tr><td>X8</td></tr></table> .....	X7	X8	12	
X7				
X8				
7. Wiring				
7-1 Wire material and max. length .....	13			
7-2 <table border="1" style="display: inline-table; vertical-align: middle;"><tr><td>X5</td></tr></table> , <table border="1" style="display: inline-table; vertical-align: middle;"><tr><td>X4</td></tr></table> connector .....	X5	X4	13	
X5				
X4				
7-3 Precautions in wiring .....	14			
8. Function				
8-1 Display of status .....	22			
8-2 Protective function .....	23			
9. 7-Segment LED display .....	25			
10. Conform to EC Directives and UL Standards				
10-1 EC Directives .....	26			
10-2 Peripheral Equipment .....	27			
10-3 Peripheral Devices Applicable to Drivers (EC directives) .....	28			
10-4 Conform to UL Standards .....	28			

## 1. Scope

This document contains specifications of the Servo Drive for AC Servo System consisting of AC Servo Motor and Servo Drive manufactured and delivered by Motor Company, Matsushita Electric Industrial Co., Ltd.

## 2. Applicable motor (Preliminary data)

And about applicable motor, 30-750W are planned.

About Model symbols, since it is still provisional, it may be changed in the future.

Model symbols are interpreted as follows:

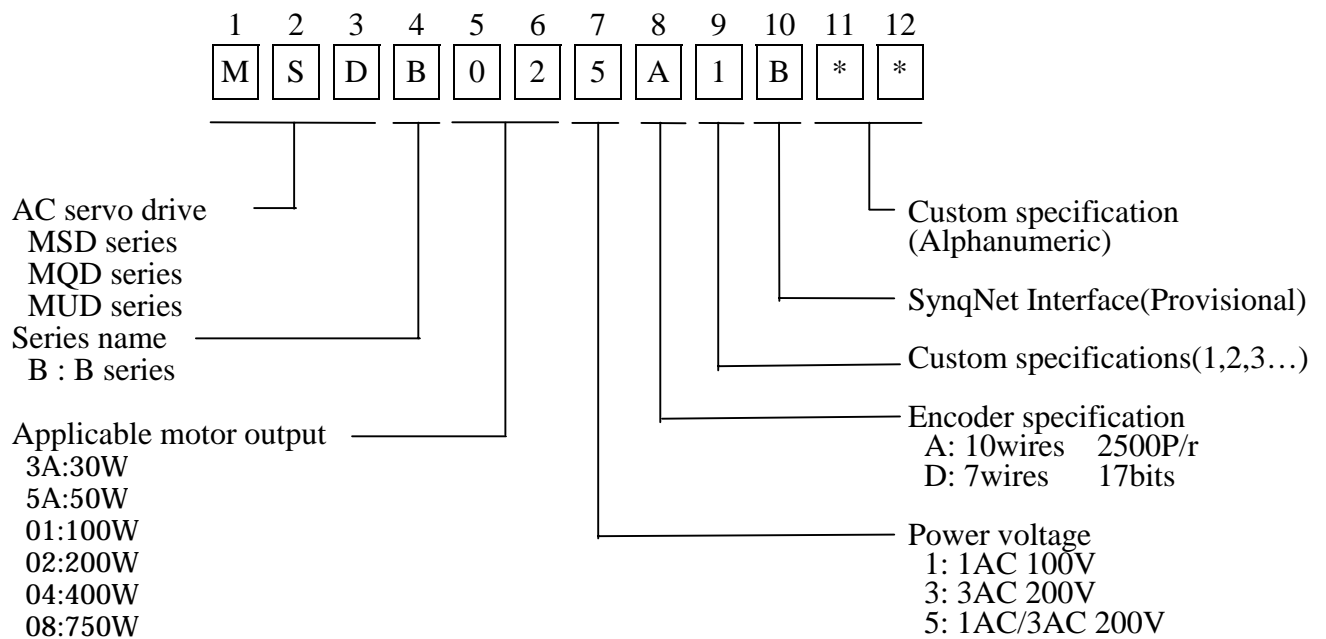

### 3. Specifications

#### 3-1 General specifications (preliminary data)

Basic specifications	Input power supply	100V system	Main circuit power supply	Single phase 100 - 115V <sup>+10%</sup> / <sub>-15%</sub> 50/60 Hz
			Control circuit power supply	Single phase 100 - 115V <sup>+10%</sup> / <sub>-15%</sub> 50/60 Hz
		200V system	Main circuit power supply	Single phase / Three phase 200 - 240V <sup>+10%</sup> / <sub>-15%</sub> 50/60 Hz <b>*750W – Three phase input Only</b>
			Control circuit power supply	Single phase 200 - 240V <sup>+10%</sup> / <sub>-15%</sub> 50/60 Hz
	Control system			Transistor PWM system (Sine wave control)
	Feedback			Incremental encoder (10 wires 2500 P/r) Absolute encoder (7 wires 17 bit)
	Working ambient conditions		Temperature	Working temperature 0 - 55°C, Storage and Transport temperature -20 - 80 °C
			Humidity	Working, Storage and Transport humidity 90%RH or less (free from dewing)
			Vibration	5.88m/s <sup>2</sup> or less, 10 - 60Hz (cannot be continuously operated at resonance point)
			Altitude	Not greater than 1000m
Function	Signal input	Control input	Emergency stop , CW (Clockwise) overtravel limit, CCW (Counterclockwise) overtravel limit ,HOME	
		Control output	Alarm, Motor Holding Brake Release	
	Signal output	Monitor output	Speed monitor Torque monitor	
		Regenerative discharge	Regenerative discharge resistor built in	
	Built-in function	Dynamic brake	Dynamic brake built in	
		Wire masking	Input signal masked, CW overtravel Limit, CCW overtravel Limit	
		Protective function	Overvoltage error, Undervoltage error, Overspeed error, Overload error, Overheat error, Overcurrent error, Encoder error, etc.	
		Alarm data trace back	Traceable last 14 times max. including the current alarm data.	
		LED Display	Link Status 7-segment LED (2 figures) for displaying error code	
		RS232 communication	Parameter set-up and control monitor can be executed by using a commercial personal computer and communication software	

## 3-2 Timing chart after power ON (preliminary data)

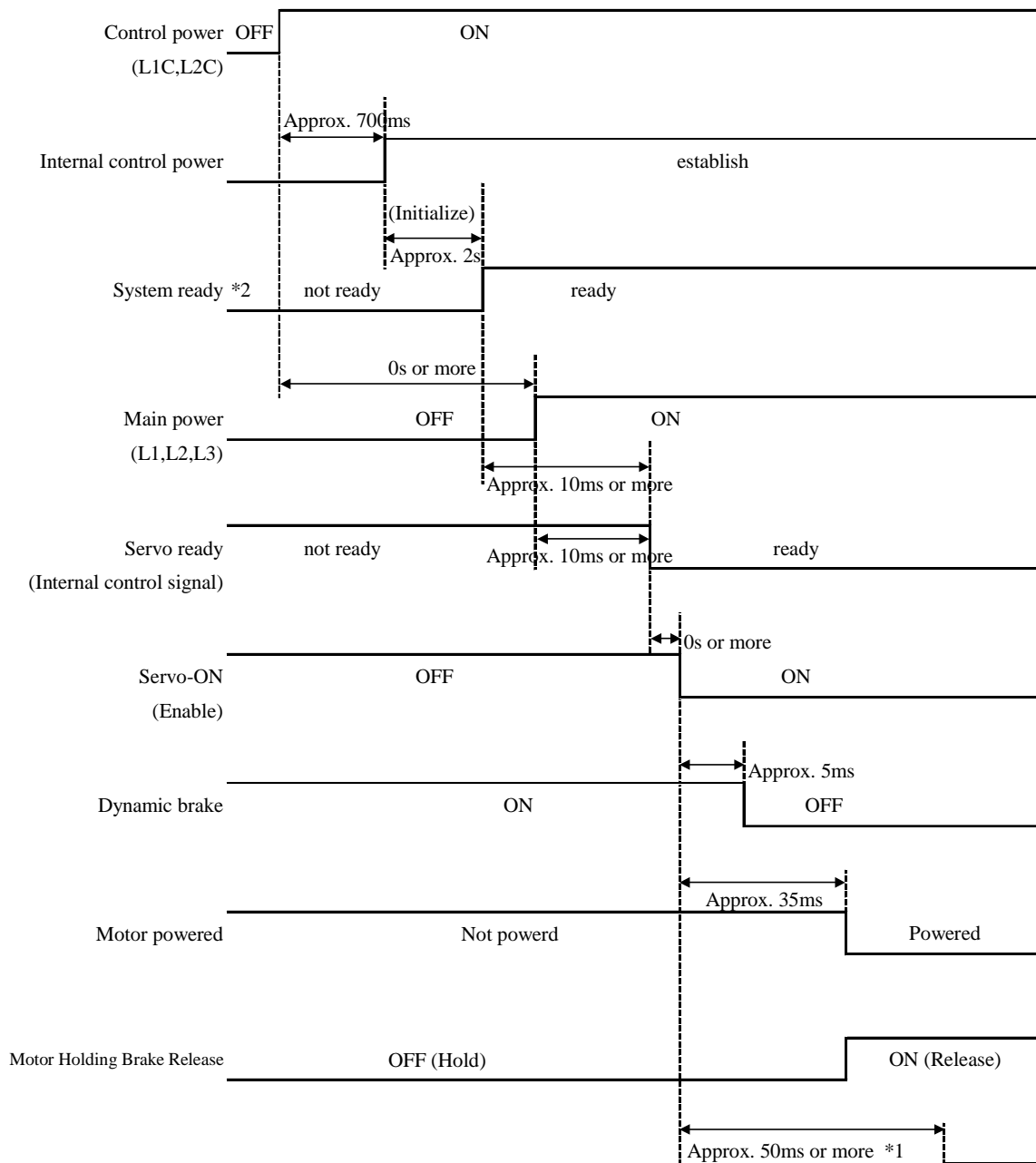

- ◆ The above shows the timing from AC power ON to command entry.
- ◆ Observe the timing of the above for Servo ON(Enable) signal and external command.

\*1 In case motor with brake is used, Command taking account of the delay time of brake release relay.

\*2 Alarm output signal becomes Active even if it is normal until the initialization of the micro computer is completed.

### 3-3 Timing chart of Servo-ON/OFF at motor standstill (servo lock) (preliminary data)

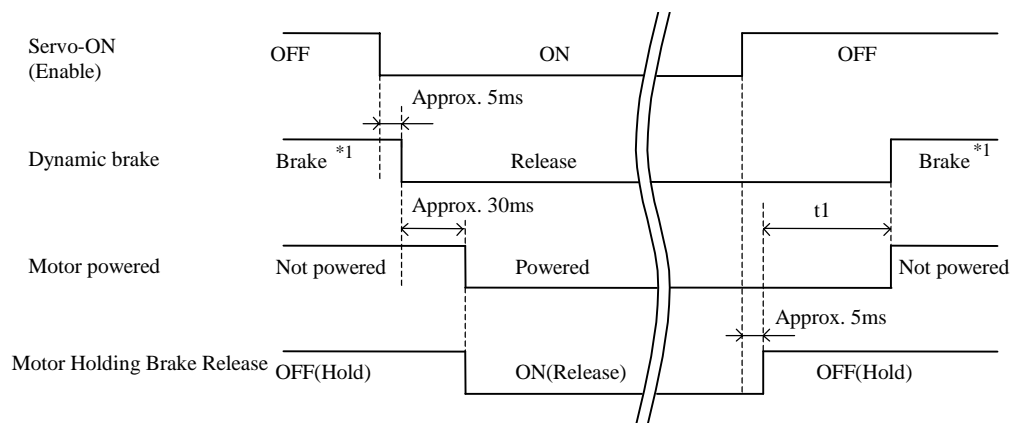

### 3-4 Timing chart of Servo-ON/OFF at motor in motion (preliminary data)

(This is to be used only at emergency, or trip. Servo-ON/OFF action to be executed after stopping the motor.)

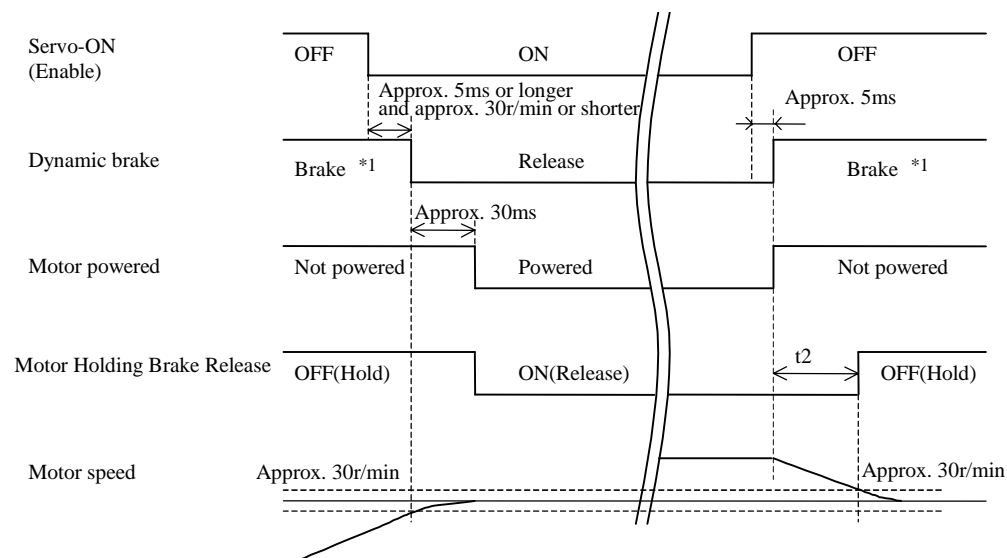

Motor standstill: Motor speed of approx. 30r/min or less

Motor in motion: Motor speed of over 30r/min.

Dynamic brake action can be set by parameter No.69, Sequence at Servo-OFF, which will be described later.

\* $t_1$  time can be set by parameter No.6A, Mechanical brake action set-up at motor in motion.

\* $t_2$  time can be set by parameter No.6B, Mechanical brake action set-up at motor standstill or required time the motor speed becomes approx. 30r/min or less (earlier time).

### 3-5 Dimensions

**Dimensional drawing: Size2**

- ◆ Base-mount type (the rear installation)
- ◆ Rack-mount type (the front installation)
  - Bracket(option) for the installation is separately necessary.

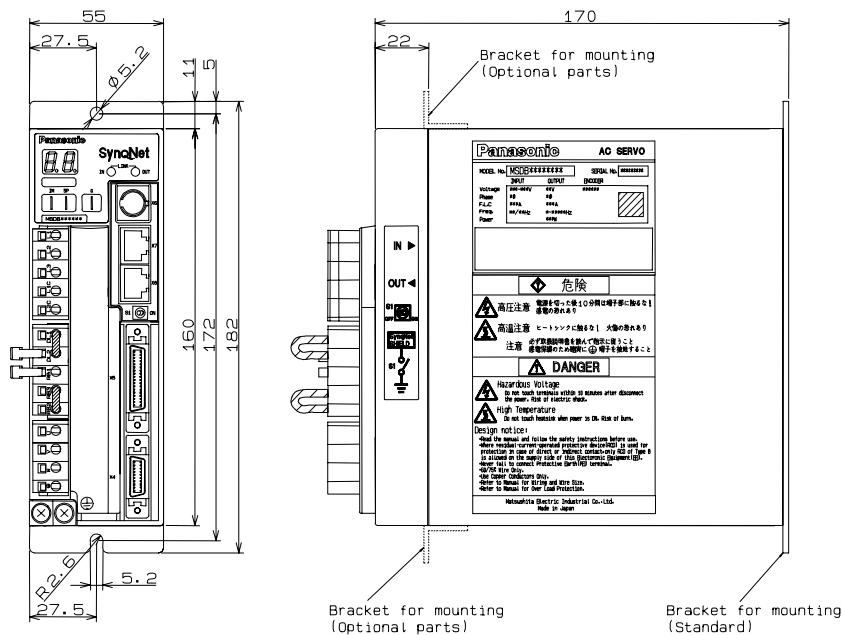

Back Panel Mount Type (Standard)

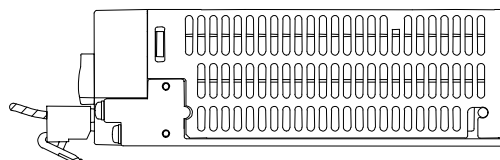

SERVO DRIVE INPUT	MOTOR OUTPUT
1AC 100 - 115V	30W
	50W
	100W
	200W
1AC/3AC 200 - 240V	30W
	50W
	100W
	200W
	400W



Dimensional drawing: Size3

- ◆ Base-mount type (the rear installation)
  - ◆ Rack-mount type (the front installation)
- Bracket(option) for the installation is separately necessary.

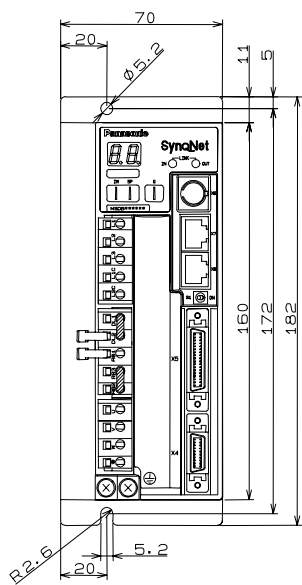

Back Panel Mount Type (Standard)

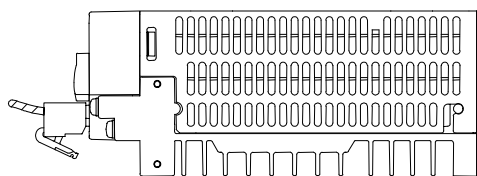
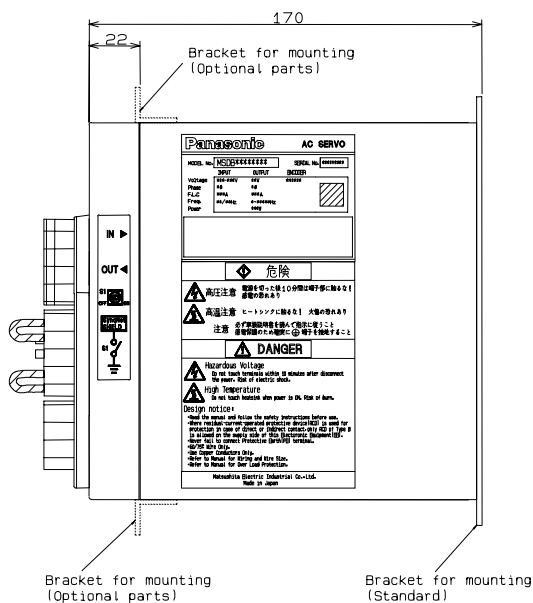

SERVO DRIVE INPUT	MOTOR OUTPUT
1AC 100 - 115V	400W
3AC 200 - 240V	750W

### 3-6 Appearance and description

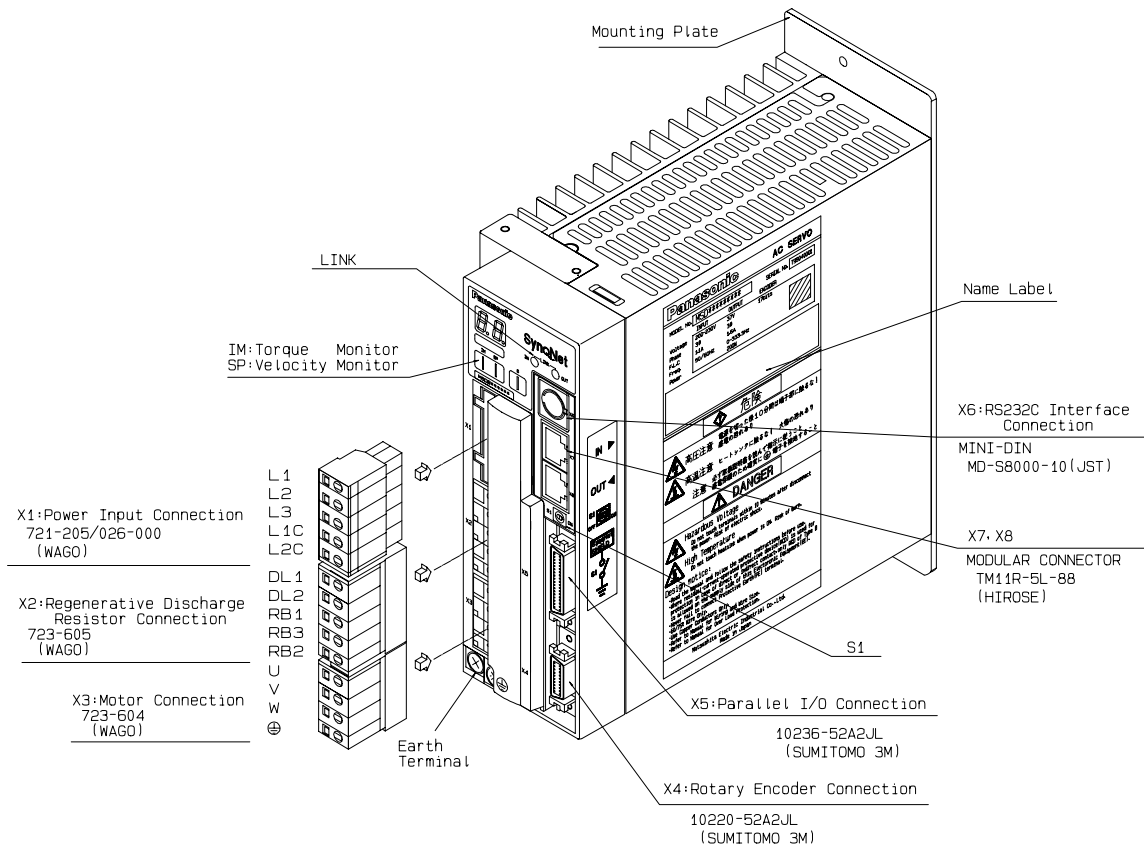

7-Segment LED for Displaying Alarm Code

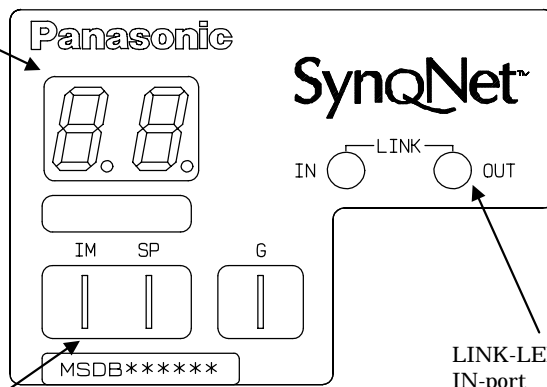

LINK-LED (Communication Status)  
IN-port OUT-port

Analogue Monitor Pin (Output Impedance : 1kΩ)

Symbol	Content
SP	Velocity
IM	Torque
G	Groun

adjust scale by changing parameters.



## Safety Precautions

### 4. Safety precautions in installing

- ◆ Provide the power supply with non-fuse breaker. Connect the ground terminal. (To prevent electric shock and malfunction, ground is recommended.) (For the earth connection, avoid direct contact between aluminum and copper or other electro-chemically incompatible materials when connecting the PE conductor.)
- ◆ Install onto nonflammable material like metals.
- ◆ Use motor and Servo Drive in specified combination.
- ◆ Carry out correct and reliable wiring. Unreliable wiring and miswriting may cause uncontrolled running and burning of the motor.
- ◆ Make sure that the input power voltage is in conformity with the Servo Drive specification before powering ON and starting operation. When the input voltage is over the rated voltage, combustion and smoking may be caused inside the Servo Drive. Uncontrolled running and burning of the motor may be sometimes caused.
- ◆ Install external emergency stop circuit to stop running and turn OFF the power immediately in case of emergency.
- ◆ Do not operate or store the machine in a place where vibration (0.6G or more) or impact is given or where there is dust or metal dust. Do not splash water, oil, and cutting oil over the machine. Keep away from combustibles, erosive gas, and flammable gas.
- ◆ Do not expose the machine to the direct rays of the sun. Store at temperature and humidity according to the specifications.
- ◆ Be careful of radiation of heat Servo Drive radiates heat as the motor runs. If it is operated in the closed control box, temperature in the control box may abnormally rise. Take care to cool so that the ambient temperature of the Servo Drive may be within the specified working range.
- ◆ Keep away from exothermic bodies such as heater or large coil resistor. (Install heat cover plates not to be influenced by exothermic bodies.)

#### **Servo Drive ambient temperature**

**Life of Servo Drive varies depending on ambient temperature.**

**Make sure that the Servo Drive ambient temperature may be within the specified range.**

#### **Working temperature range**

**0 - 55 °C**

### 6. Safety precaution in operating

- ◆ Never touch the inside of Servo Drive. Contact us or our authorized dealer for overhaul.
- ◆ Some time after power OFF, the internal circuit is charged to high voltage. Before moving, wiring, or inspecting, completely shut off the power input outside the Servo Drive. Leave it for 10 minutes or more and then start working.
- ◆ During the power is ON, keep away from the motor and the machine driven by the motor to provide against malfunction.
- ◆ When not in use for a long time, turn OFF the power supply.
- ◆ When alarm is output, remove the cause and then restart. If restarted without removing the cause, the motor may unexpectedly run or burn out.
- ◆ Capacity of power rectifying circuit capacitor decreases due to secular change. To prevent secondary damage caused by failure, it is recommended to replace the capacitor every five years. For replacement, contact us or our authorized dealer.
- ◆ To prevent electric shock, install cover onto the LED touch panel terminal block.

**Take every possible care to secure safety against unexpected action. Every effort is made to secure high quality of this product, but unexpected action beyond setting may be caused by too high external noise, static electricity, abnormal input power supply, incorrect wiring, or defective parts.**

## 6. Connector

X1	(WAGO 721-865/001-000)
----	------------------------

## 6-1 Power connector

X2	(WAGO 722-835)
----	----------------

X3	(WAGO 722-834)
----	----------------

Terminal symbol	Name	Description	
L1, L2, L3	Main power supply input terminal	100V	Inputs single-phase 100-115V <sup>+10%</sup> <sub>-15%</sub> 50/60Hz to L1 and L3 terminals.
		200V	Inputs 3-phase or single-phase 200-240V <sup>+10%</sup> <sub>-15%</sub> 50-60Hz.
L1C, L2C	Control power supply input terminal	100V	Inputs single-phase 100-115V <sup>+10%</sup> <sub>-15%</sub> 50/60Hz.
		200V	Inputs single-phase 200-240V <sup>+10%</sup> <sub>-15%</sub> 50-60Hz.
DL1, DL2	DC Reactor Terminal	Connects to DC reactor (provided Customer) In normal application, short-circuits between DL1 and DL2.	
RB1, RB2, RB3	Regenerative discharge resistor connecting terminal	In normal application, short-circuits between RB3 and RB2, and use the built-in regenerative discharge resistor. Set a regen register (selected a size of register by a customer) between RB1 and RB2 after RB3 and RB2 opened, if the built-in register is not large enough.	
U,V,W	Motor connecting terminal	Connects to each phase coil of motor.	
	Earth terminal	Connects to motor E-terminal to ground.	

6-2 Encoder connector **X4** (SUMITOMO 3M 10220-52A2JL)

Application	Connector Pin No.	Description	
		Incremental	Absolute
Encoder power supply output	1,2	E0V <sup>(Note1)</sup>	
	3,4	E5V	
Battery (+) (For absolute encoder)	5	Do not connect.	BTP-O
Battery (-) (For absolute encoder)	6	Do not connect.	BTP-O
Encoder signal input (A phase)	7	A	Do not connect.
	8	A	Do not connect.
Encoder signal input (B phase)	9	B	Do not connect.
	10	B	Do not connect.
Encoder signal input (Z phase)	11	Z	Do not connect.
	12	Z	Do not connect.
Encoder signal input (serial signal)	17	PS	
	18	$\overline{\text{PS}}$	
Frame ground	20	FG	

Note 1: Encoder power supply output 0V is connected to the control circuit ground connected to Connector **X5**.

Note 2: Do not connect to Pins (13, 14, 15, 16, 19) excepting pins in the above table.

Note 3: The battery is unnecessary if absolute encoder is used as incremental.

6-3 Interface connector **X5** (SUMITOMO THREE M 10236-52A2JL)

Function	Symbol	Connector Pin No.	Contents
Common input for control (input) signal power	I-COM	1	DC12-24V Connect to positive pole of external DC power.
Emergency stop input	EMG-STP	2	Get tripped with emergency stop when not connected to I-COM.
CW overtravel limit input	CWL	20	No CW torque when not connected to I-COM.
CCW overtravel limit input	CCWL	19	No CCW torque when not connected to I-COM.
Slowdown homing signal input	$\overline{\text{HOME}}$	21	Connect sensor signal when it is connected to I-COM-. At slowdown homing signal input.
User input	User I_A0	29	(Reserved)
	User I_B0	30	(Reserved)
	User I_C0	22	(Reserved)
Direction Selectable User I/O	Xcvr0A+	3	(Reserved)
	Xcvr0A-	4	
	Xcvr0B+	5	(Reserved)
	Xcvr0B-	6	
	Xcvr0C+	7	(Reserved)
	Xcvr0C-	8	
	Xcvr0D+	9	(Reserved)
	Xcvr0D-	10	
	Xcvr0E+	23	(Reserved)
	Xcvr0E-	24	
	Xcvr0F+	25	(Reserved)
	Xcvr0F-	26	
Gnd	GND	11,27,28	Signal ground.
Analog input	Analog_IN_X+	13	General purpose analogue input. Unisolated, complementary.
	Analog_IN_X-	14	
Analog gnd	Agnd	12	Analog ground.
Common input for control (output) signal power	O-COM	17	DC12-24V Connect to negative pole of external DC power.
Alarm output	ALM+	15	Output transistor turns off when error happens.
	ALM-	16	
Motor Holding Brake Release output	MBR+	36	Output transistor turns on when the motor holding brake is released.
	MBR-	35	
User Output	UserO_A0+	31	(Reserved)
	UserO_A0-	32	
Absolute encoder battery	BTP-I	34	Connects backup battery for absolute encoder. TOSHIBA BATTERY ER6V 3.6V recommended.
	BTN-I	33	
Frame ground	FG	18	It is connected to frame ground (chassis)

6-4 RS232 Serial communication connector **X6** (JST MD-S8000-10 or its equivalent)

Serial communication with personal computer can be executed using RS232.

6-5 SynqNet Communication connector **X7** **X8** (HIROSE TM11R-51-88 or its equivalent)

## X7 connector ("IN" Port)

No.	Symbol	Description
1	TD+	Transmit data
2	TD-	
3	RD+	Receive data
4	-	Not used
5	-	
6	RD-	Receive data
7	-	Not used
8	-	





Note: Use to connector with gilded a terminal.

## X8 connector ("OUT" Port)

No.	Symbol	Description
1	RD+	Receive data
2	RD-	
3	TD+	Transmit data
4	-	Not used
5	-	
6	TD-	Transmit data
7	-	Not used
8	-	



## 7. Wiring

### 7-1 Wire material and max. length

Name	Symbol	Max. length	Wire
Main power supply	L1, L2, L3	-	According to attached specifications of each model
Control power supply	L1C, L2C	-	HVSF 0.75mm <sup>2</sup> *1
Motor connecting	U, V, W, 	20m	According to attached specifications of each model
Earthing		1m	According to attached specifications of each model
Encoder connecting		20m	Shielded twist pair wire, Wire: 0.18mm <sup>2</sup> or more
Input / Output connecting		3m	

\*1 Please refer to EN60204-1.

### 7-2 , connector

Connector symbol	Parts name	Parts No.	Manufacturer
	Solder plug	10136-3000VE	SUMITOMO 3M
	Shell kit	10336-52A0-008	
	Solder plug	10120-3000VE	
	Shell kit	10320-52A0-008	

Use the above product or its equivalent.



## 7-3 Precautions in wiring

## (1) Wiring to Power connector

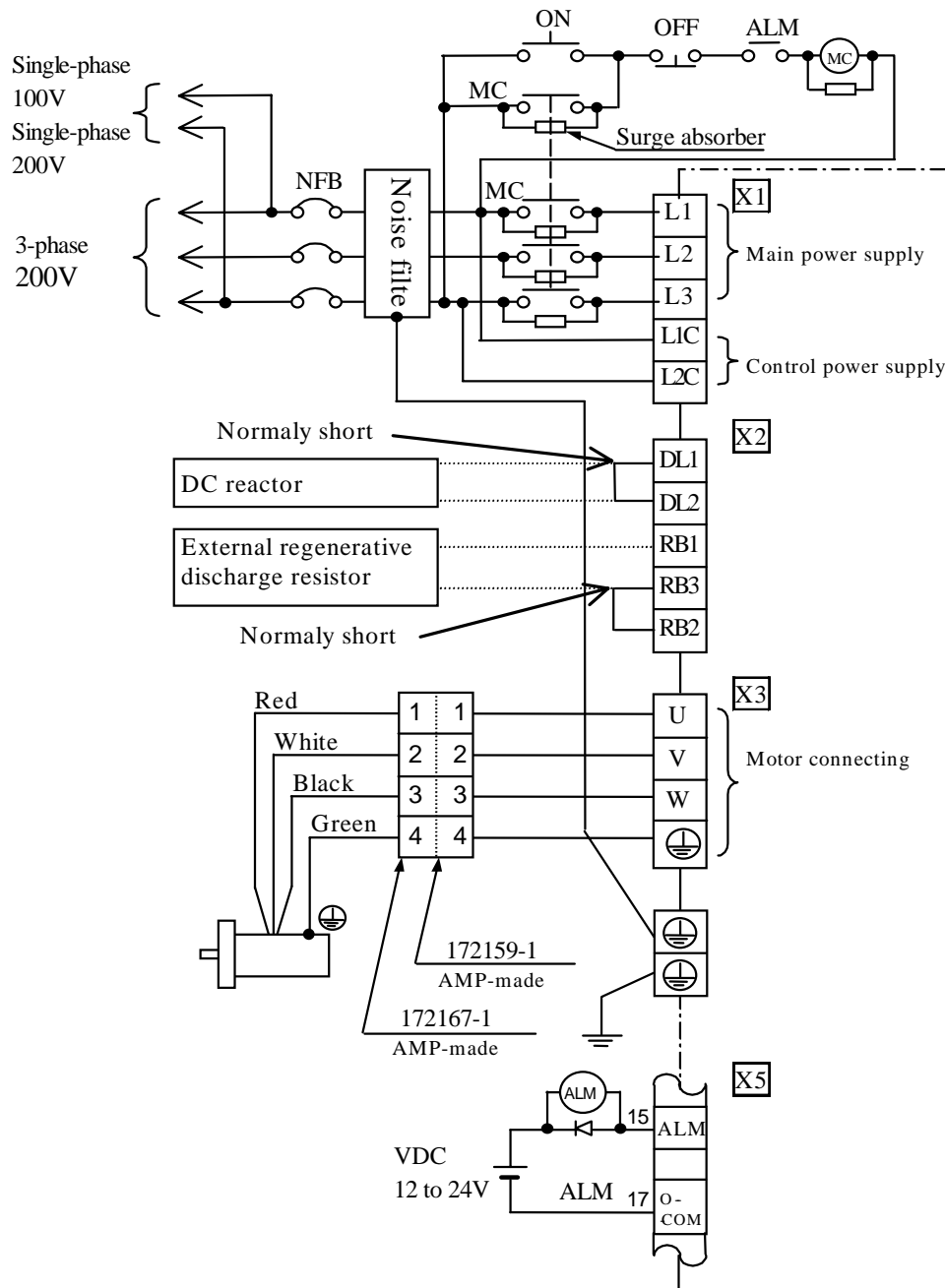

- ◆ Make sure to wire correctly according to the above fig.
- ◆ When you use with power source single phase input, connect to main power input terminals L1 and L3. Do not connect to L2.
- ◆ When you put DC reactor, remove the wiring between DL1 and DL2 and put DC reactor between them.
- ◆ Regenerative discharge resistor is built in. To use this resistor, connect between RB2 terminal and RB3 terminal. If the built-in regenerative discharge resistor power is insufficient (the Servo Drive trips displaying the error No. 18, Regenerative discharge load protection error), install an external regenerative discharge resistor. When installing external regenerative discharge resistor, remove the connecting bar between RB2 terminal and RB3 terminal and connect the external resistor between RB1 and RB2.

- ◆ Apply the specified power voltage as shown on the name label.
- ◆ Do not connect the power input terminals (L1, L2, L3) and motor output terminals in reverse.
- ◆ Prevent ground fault and short circuit of motor output terminals (U, V, W).
- ◆ High voltage is applied to terminals X1, X2, X3. Never touch them, or electric shock may be caused. Unlike induction motor, rotational direction of AC servo motor cannot be switched by changing 3 phases.
- ◆ Securely connect motor earth terminal and Servo Drive earth terminal to ground at a point together with noise filter earth terminal. Also ground the machine main body (grounding resistance 100Ω or less).
- ◆ Insert surge absorbing circuit into the peripheral electric magnetic conductor, relay contacts/coils, and brake coil of motor with brake to prevent noise.
- ◆ Install non-fuse breaker to shut off the power outside the Servo Drive in emergency. Leakage breaker, if used, should be of high frequency resisting type.
- ◆ Install noise filter to reduce terminal noise voltage.
- ◆ Power supply for the brake of motor with brake should be provided by the customer.
- ◆ Do not turn power on until wiring and connections are completed.

## &lt;Procedure for connecting a wire to the power connector&gt;

Connect a wire to the power connector X1,X2,X3 with the following procedure.

Procedure
-----------

1. Peel a use wire.

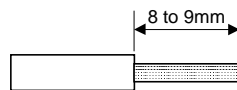

2. Insert a wire in the connector.

There are two methods to show in the following in the insertion work.

- (a) Insert a wire by using the attached lever.
- (b) Insert a wire by using a minus screwdriver (edge width 3.0 to 3.5mm) or either 210-120J, 210-350/01 or 270-258J manufactured by WAGO co. of Japan ltd.

- (a) If you use the attached lever

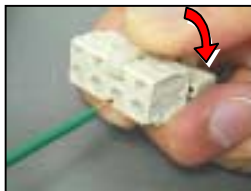

(1) Push the lever installed in the upper slot by the finger, and push down a spring.



(2) Insert a wire until it runs into the insertion mouth (circle hole) with pushing the lever.

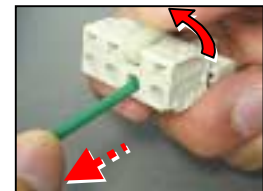

(3) The wire can be connected if you let the lever go.

- (b)-1 If you handle the screwdriver .1



(1) Insert a screwdriver in the slot (corner hole). The screwdriver is held if it is inserted properly.



(2) Insert a wire until it runs into the insertion mouth (circle hole).



(3) The wire can be connected if you let the screwdriver go.

- (b)-2 If you handle the screwdriver .2



(1) Put a special tool screwdriver on the upper slot, and push down a spring.



(2) Insert a wire until it runs into the insertion mouth (circle hole).

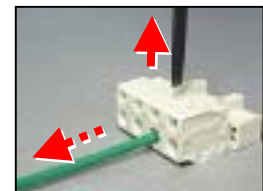

(3) The wire can be connected if you let the screwdriver go.

\* A wire can be removed in the same way as the insertion work.

Note)

- ◆ Protect Peeled length of a wire.
- ◆ Connect a wire after you remove a connector from the servo amplifier.
- ◆ Insert one wire into one wire insertion mouth of the connector.

(2) Wiring to connector **X5**

- ◆ Control signal power supply of DC12-24V for external control need to be provided by the customer.
- ◆ The distance between the Servo Drive and peripheral equipment should be as short as possible (within 3m) to decrease wiring length.
- ◆ In wiring keep away from power lines (L1, L2, L3, L1C, L2C, U, V, W, ) (30cm or more).

**Control input**

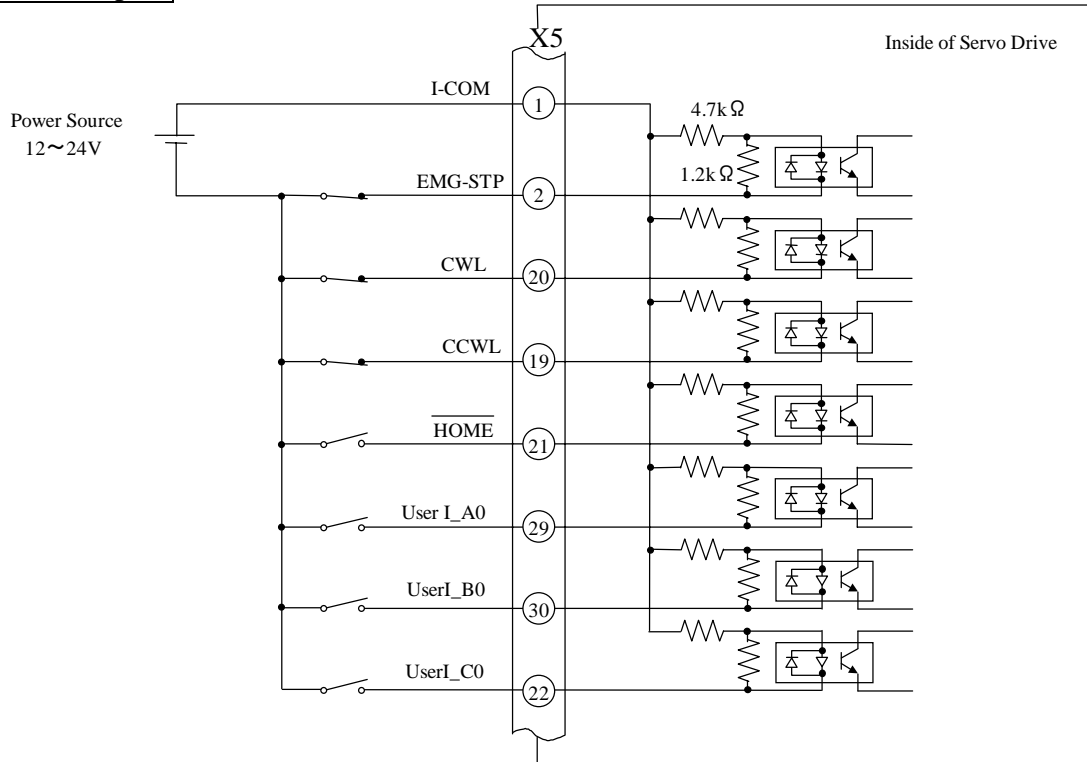

### Control output

- ◆ Select a correct polarity of the control signal power supply. Reverse connection could damage the Servo Drive.
- ◆ When relay is directly driven by each output signal, install a diode in parallel with the relay in the direction as shown below. No diode installation or reverse installation could damage the Servo Drive.
- ◆ When each output signal is received by gate or other logic circuit, take care not to be influenced by noise.
- ◆ Supply current of 50mA or less to each output.

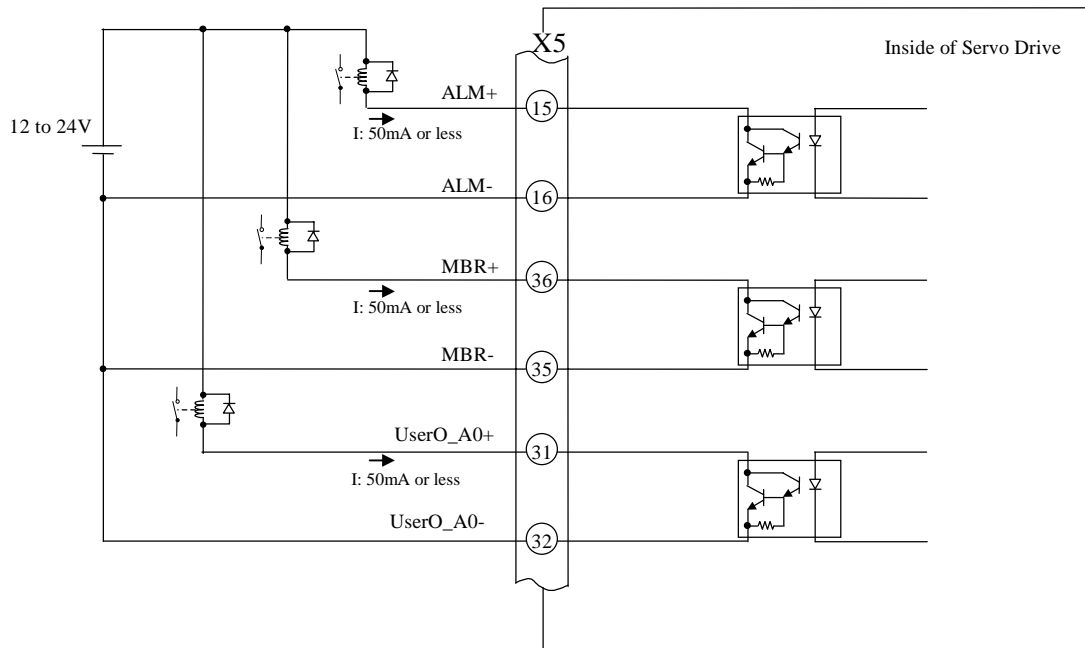

### Analog input

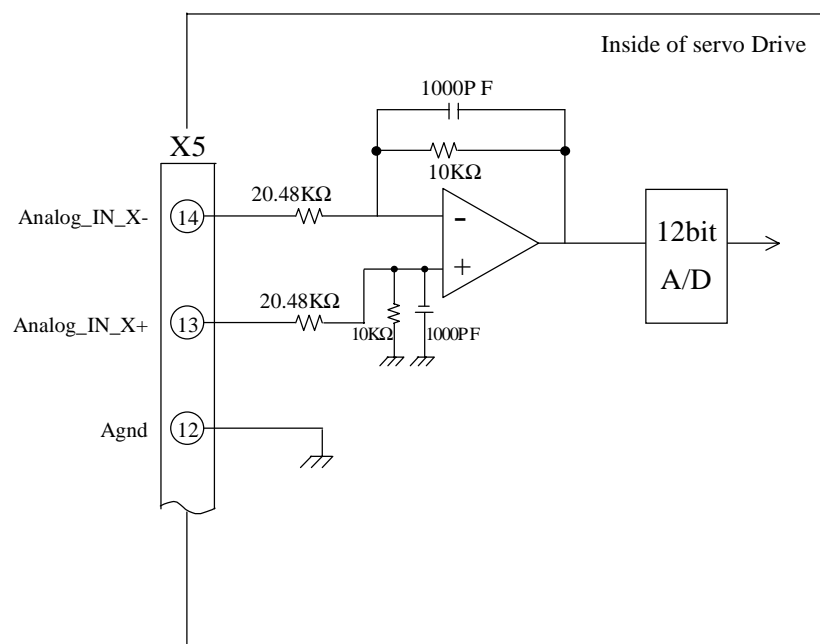

Direction Selectable User I/O

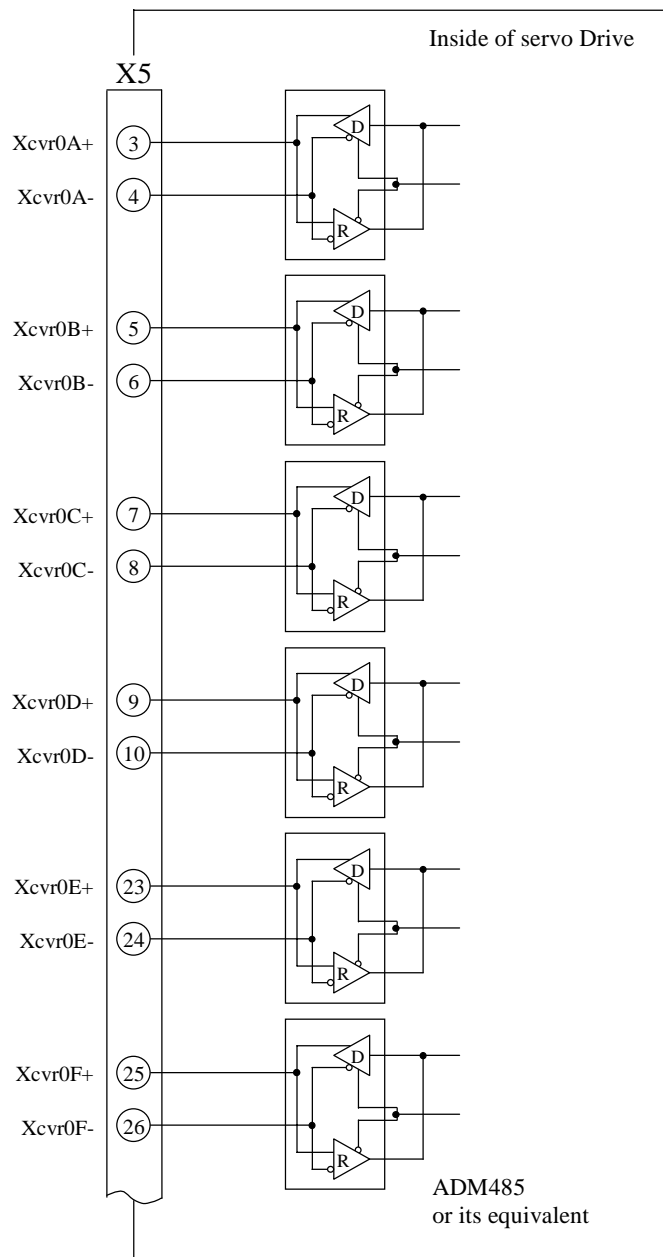

(3) Wiring to connector **X6**

- ◆ Use shielded twisted pair cable of 0.18mm<sup>2</sup> or more stranded wires as encoder cable.
- ◆ Cable length should be 20m max. When wiring is long, double wiring is recommended to 5V power supply to reduce influence by voltage drop.
- ◆ Connect shielded wire housing on the motor side to the shield of shielded wire from encoder.
- ◆ Connect shielded wire housing on the Servo Drive side to **X4** Pin 20 (FG).
- ◆ Keep away from power line (L1, L2, L3, L1C, L2C, U, V, W, ⊕ ) wiring (30cm or longer).
- ◆ Do not put them into a duct. Do not tie them.
- ◆ Do not connect to **X4** empty pin.

10 wires incremental encoder

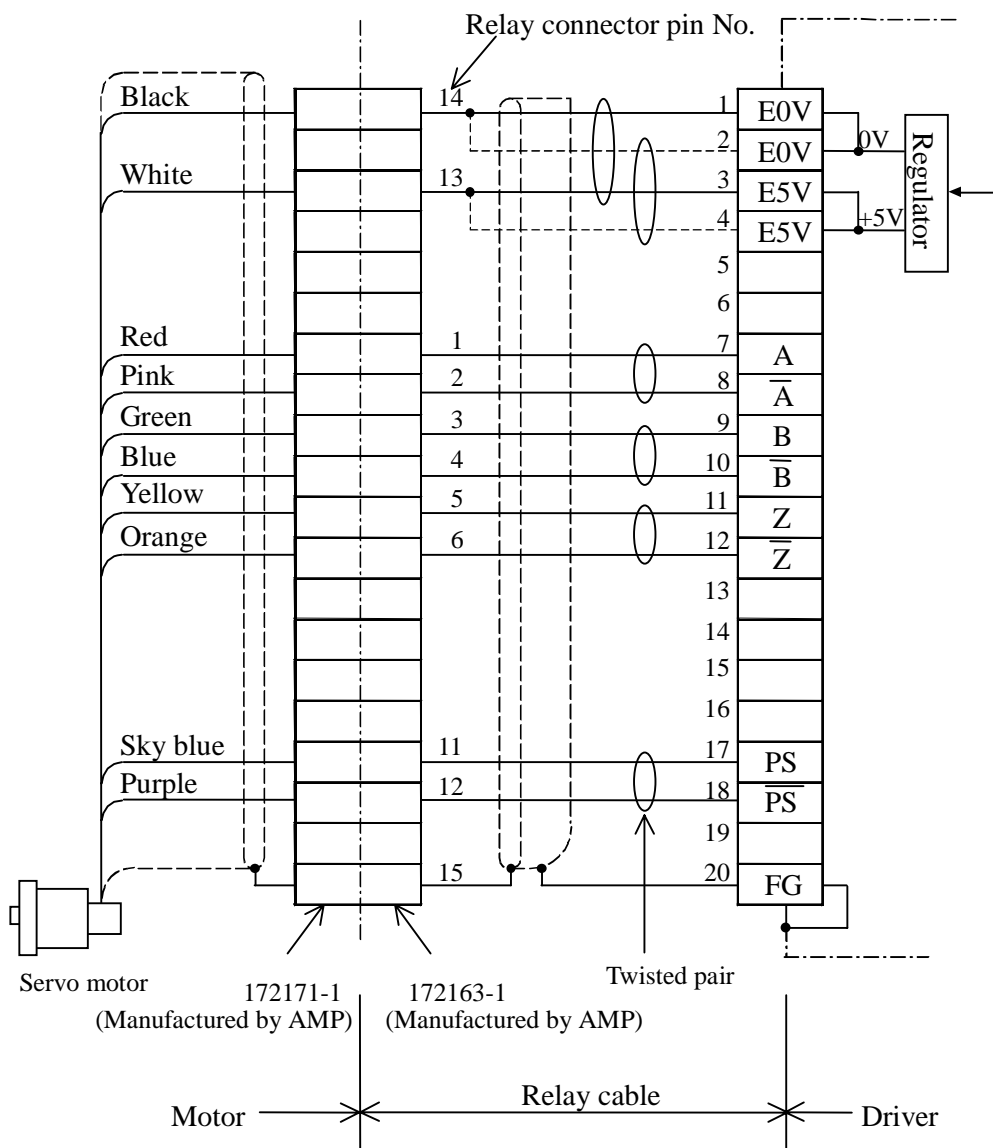

7 wires absolute encoder

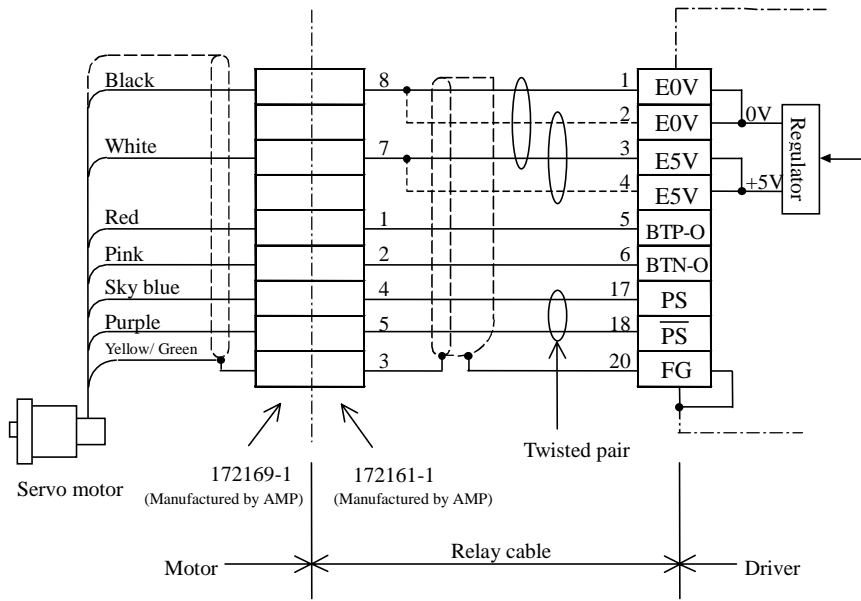



## 8. Function

### 8-1 Display of status (Preliminary data)

This Servo Drive displays the status of network with LINK LED.

LED	Display	Contents
LINK	Off	Off line status.
	Solid Green	Connection is established.

Note) It may be changed in the future since it is still provisional.

## 8-2 Protective function (Preliminary data)

This Servo Drive has protection functions built-in.

When these functions work, Servo Drive makes alarm output signal (ALM) off and gets tripped. Then error code number on 7 segment LED of the front panel.

Protective function	Error code No.	Observation	Remedy or action to follow
Overheat error	15	Servo Drive power elements are abnormally heated.	•Check Servo Drive ambient temperature and cooling conditions.
Overvoltage, main power	12	Converter voltage increases due to regenerative energy. 200V model: 400VDC or more, 100V model: 200VDC or more	•Increase deceleration time or lower the load inertia. Note: Not applicable to which the regenerative brake is continuously used.
Undervoltage, control power	11	Power voltage drops due to instantaneous power failure or short capacity of power supply	•Check if power voltage is within the permissible voltage range.
Encoder A/B-Phase error	20	Encoder line has troubles such as disconnection. Encoder is defective.	•Check if encoder connection has any trouble and check the connected state at connector <span style="border: 1px solid black; padding: 0 2px;">X4</span> . •Check the power voltage (5V±5%) on the encoder side. (Take care when encoder cable is long.)
Encoder communication error	21		
Encoder connection error	22		
Encoder communication data error	23		
Overload error	16	Servo Drive is continuously operated exceeding the rated current.	•Increase acceleration /deceleration time or lower the load. Increase motor and Servo Drive capacity.
Overspeed error	26	Motor speed exceeds the velocity limit.	•Check if excess speed command is given. Check if acceleration overshoot is generated due to gain adjustment failure.
Undervoltage, main power	13	Power voltage drops due to instantaneous power failure or short capacity of power supply	•Check if power voltage is within the permissible voltage range. Note: Be careful of short power capacity, voltage drop due to rush current at powering ON, and open-phase of power supply.
Regenerative discharge error	18	Regenerative energy is exceeding the permissible regenerative discharge resistor value.	•Connect external regenerative discharge resistor.
EEPROM parameter error	36	EEPROM parameter error occurs if the data is broken when data is read from EEPROM at power ON.	•Reset all the parameters and write into EEPROM.
EEPROM check code error	37		•The Servo Drive might be defective. Ask the sales agent.

Protective function	Error code No.	Observation	Remedy or action to follow
Overcurrent error	14	Converter output current is abnormally high.	<ul style="list-style-type: none"> <li>• After power supply is completely shut off, check if motor connecting wire U, V, W are not short-circuited with one another.</li> <li>• Check insulation resistance between motor connecting wire U, V, W and motor earth E, and check if motor insulation is reduced or not.</li> </ul>
Emergency stop input error	39	The Servo Drive gets tripped when emergency stop input becomes active.	<ul style="list-style-type: none"> <li>• Check if anything wrong with switch (sensor), electric lines and power source which are connected to emergency stop input.</li> <li>• Make sure that emergency EMG-stop input (X5 2pin) generally close.</li> <li>• Check if power of control signal (DC12 to 24V) is started later compared to the Servo Drive when power is turned on.</li> </ul>
Absolute system down error	40	All the power supplies for the encoder are down.	<ul style="list-style-type: none"> <li>• After connecting battery, execute absolute clear.</li> </ul>
Absolute encoder counter overflow error	41	Encoder multi-turn counter exceeds the specified value.	<ul style="list-style-type: none"> <li>• Set parameter No.0B absolute encoder set-up to appropriate value.</li> <li>• Moving amount from the machine home should be within 32767 turns.</li> </ul>
Absolute encoder overspeed error	42	Turning amount exceeds the specified value when battery power alone is supplied.	<ul style="list-style-type: none"> <li>• Check CN SIG connection state.</li> <li>• Check power voltage (5V+/-5%) on the encoder side.</li> </ul>
Absolute encoder single-turn counter error	44	Encoder detects single-turn counter error	<ul style="list-style-type: none"> <li>• The motor might be defective. Ask the sales agent.</li> </ul>
Absolute encoder multi-turn counter error	45	Encoder detects multi-turn counter error	
Absolute encoder status error	47	Encoder is running higher than the specified value at the power ON.	<ul style="list-style-type: none"> <li>• Prevent the motor from running when powered ON.</li> </ul>
Other errors	Nos. other than the above	The Servo Drive trips when internal self-diagnosis function is activated, judging some abnormality.	Turn off the power, and next turn on again. If the Servo Drive still trips displaying the left message, the Servo Drive might be defective. Immediately shut off the power.

- ◆ Overload error can be cleared approx. 10 seconds after the error occurs.

### 9. 7-segment LED display (Preliminary data)

In case of Alarm, the servo-amplifier turns on and off Alarm code with 2 digit-decimal number on the front panel. The other Alarm codes are shown below.

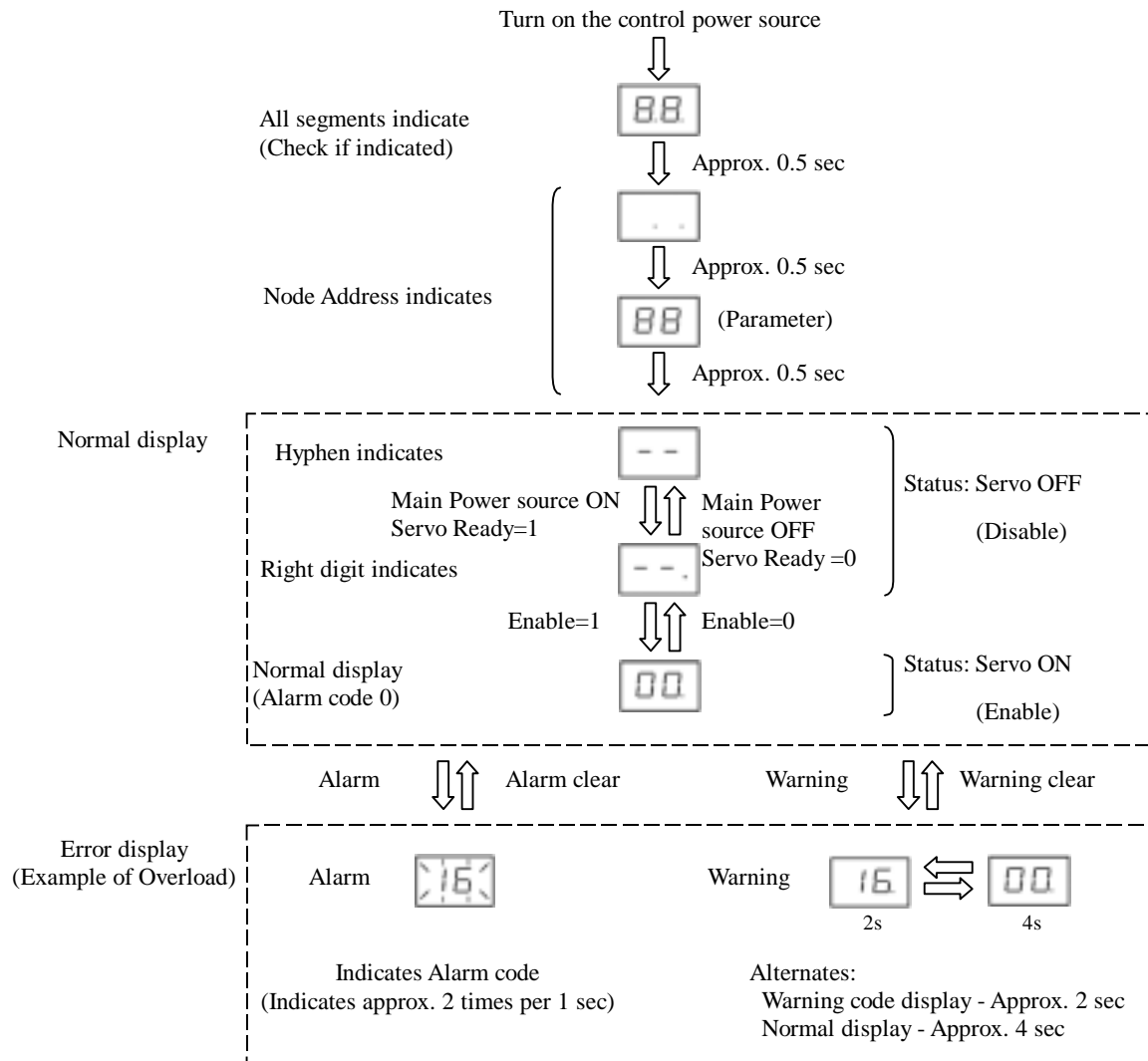

The content of the Alarm code is the same as the warning's. Except for Battery warning, Warning display goes back to Normal display if there is no error factor. Until Alarm clear is executed, both Battery Warning display and Alarm display remain even after there is no error factor.

\* Warning display function is not implemented yet as of May 22, 2002.

## 10. Conformance to EC Directives and UL Standards

### 10-1 EC Directives (Plan to take)

The EC Directives apply to all such electronic products as those having specific functions and directly sold to general consumers in EU countries. These products are required to meet the EU unified standards and to be furnished with CE Marking.

Our product, AC servo, has specific functions, but is not sold directly to general consumers. i.e. this product is regarded as a component that constitutes a machine or equipment. Therefore, the product (AC servo) is not required to be furnished with CE Marking.

However, our AC servos meet the EC Directives for Low Voltage Equipment so that the machine or equipment comprising our AC servos can relevant EC Directives.

#### (1) EMC Directives (Plan to take)

Our servo systems can meet EMC Directives and related standards. However, to meet these requirements, the systems must be limited with respect to configuration and other aspects, e.g. the distance between the Servo Drive and motor is restricted, and some special wiring conditions must be met. This means that in some cases machines and equipment comprising our servo systems may not satisfy the requirements for wiring and grounding conditions specified by the EMC Directives. Therefore, conformance to the EMC Directives (especially the requirements for emission noise and noise terminal voltage) should be examined based on the final products that include our Servo Drives and servo motors.

#### (2) Applicable Standards (Planed)

Subject	Applicable standards	
Motor	IEC60034-1	Standards referenced by Low-Voltage Directive
Motor and Servo Drive	EN50178	
	IEC61800-3 EMC Requirements for Variable Speed Electric Power Driven Systems	Standards referenced by EMC Directives
	IEC61000-4-2 Electrostatic Discharge Immunity Test	
	IEC61000-4-3 Radio Frequency Electromagnetic Field Immunity Test	
	IEC61000-4-4 Electric High-Speed Transition Phenomenon-Burst Immunity Test	
	IEC61000-4-5 Lightning Surge Immunity Test	
	IEC61000-4-6 High Frequency Conduction-Immunity Test	
	IEC61000-4-11 Instantaneous Outage-Immunity Test	

IEC : International Electrical Commission

EN : Europaischen Norman

EMC : Electromagnetic Compatibility

## 10-2 Peripheral Equipment

### (1) Environment

The Servo Drive should be used under Pollution Level 2 or 1 specified by IEC60664-1 (housing the Servo Drive in an IP54 control box).

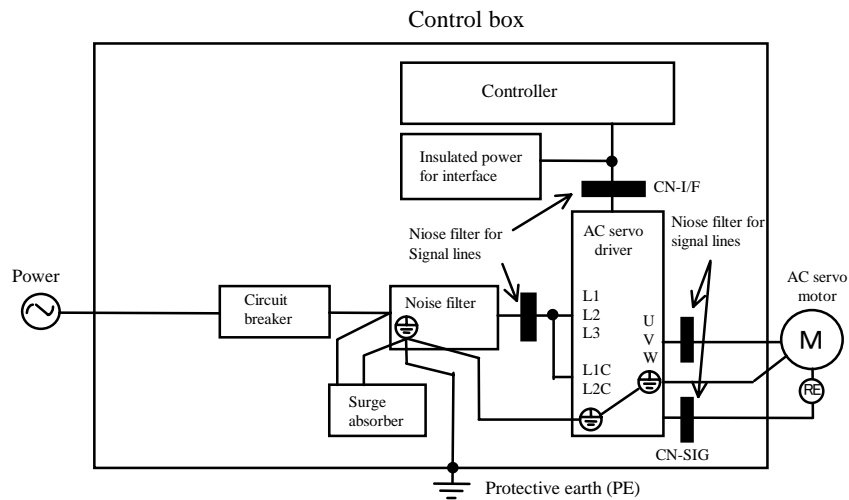

### (2) Power

100V system : Single-phase 100 to 120V +10%/-15%, 50/60Hz

200V system : Three-phase & Single-phase 200 to 230V +10%/-15%, 50/60Hz

- (1) Use under the environment of Over-voltage Category 3 specified by IEC60664-1.
- (2) The power for interface should be marked CE or EN Standard (EN60950) type, 12VDC to 24VDC, insulated.
- (3) Circuit Breaker

Install a circuit breaker between the power supply and noise filter. The circuit breaker should be IEC Standard and UL listed (UL) marked.

#### (4) Noise Filter

If several Servo Drives are used, and a single noise filter is installed at the power supply, consult the manufacturer of the noise filter.

#### (5) Surge Absorber

Install a surge absorber at the primary side of the noise filter.

#### <Notes>

When performing a voltage-resisting test, remove the surge absorber. Otherwise the absorber may be damaged.

#### (6) Install noise filters

Install noise filters (specially designed for signal wires) for all cables (power, motor, encoder and interface wires).

#### (7) Grounding

- (7-1) Connect between the Servo Drive's protective earth terminal (PE) and control box's protective earth (PE) to prevent electric shocks.
- (7-2) Multiple connections to a single protective earth terminal (PE) should be avoided. There are two protective earth terminals.
- (7-3) Where residual-current-operated protective device (RCD) is used for protection in case of direct or indirect contact, only RCD of Type B is allowed on the supply side of this Electronic equipment (EE). Otherwise another protective measure shall be applied such as separation of the EE from the environment by double or reinforced insulation or isolation of EE and supply system by a transformer.

## 10-3 Peripheral Devices Applicable to Servo Drives (EC Directives)

Servo Drive's Series No.	Voltage	Output rating	Circuit breaker (current rating)	Noise filter	Surge absorber	Noise filter for signal lines
MSD	100V	30W~200W	10A	DV0P1441	DV0P1450	DV0P1460
		400W	15A	DV0P1442		
	200V	30W~400W	10A	DV0P1441		
		750W	15A	DV0P1442		

	Option Part No.	Manufacturer's Product No.	Manufacturer
Surge Absorber	DV0P1450	R-A-V-781BXZ-4	Okaya Electric Industries Co., Ltd.
Noise Filter For Signal Lines	DV0P1460	ZCAT3035-1330	TDK Corporation
Noise Filter	DV0P1441	3SUP-A10H-ER-4	Okaya Electric Industries Co., Ltd.
	DV0P1442	3SUP-A30H-ER-4	

## 10-4 Conform to UL Standards (Plan to take)

The noise filters conform to UL508C (File No. E164620) to satisfy the following conditions.

- (1) The Servo Drive should be used under Contamination Level 2 or 1 specified by IEC60664-1 (housing the Servo Drive in an IP54 control box).
- (2) Install a circuit breaker or fuse between the power supply and noise filter. The circuit breaker or fuse should be a UL listed (U) marked type. The current rating of the circuit breaker or fuse should be per the table in 14-3.  
For wiring, use copper conductor wire (rated temperature: 60°C or more).